

Advantage Products Enterprise, Inc.  
Single Point Suspension for Pro Audio speaker installation

[www.aperigging.com](http://www.aperigging.com)

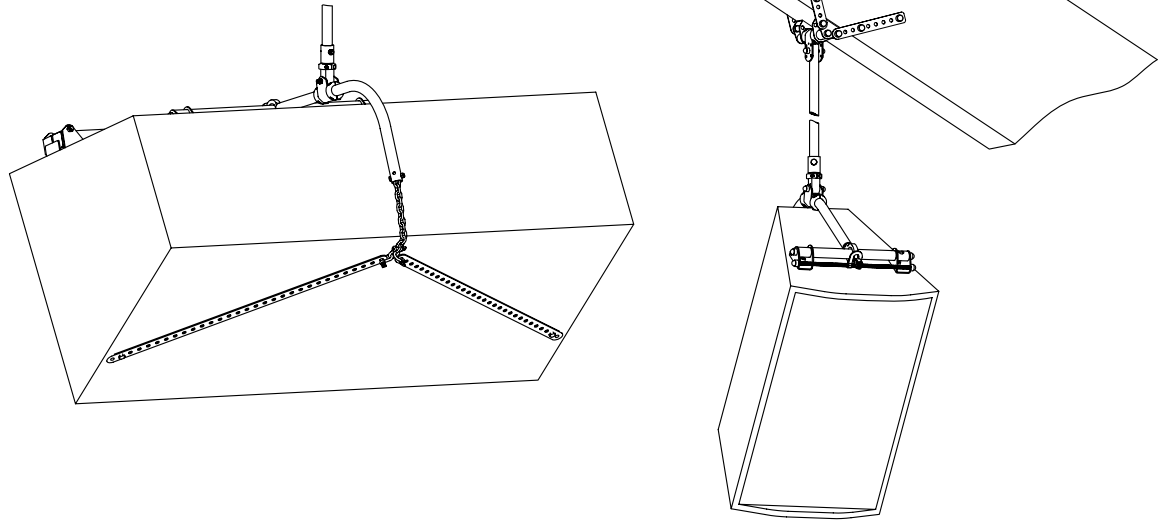

## STRIP Sling™

11 gauge ASTM A1011 HSLA grade 50 steel strips  
for low profile bridles and miscellaneous load securement

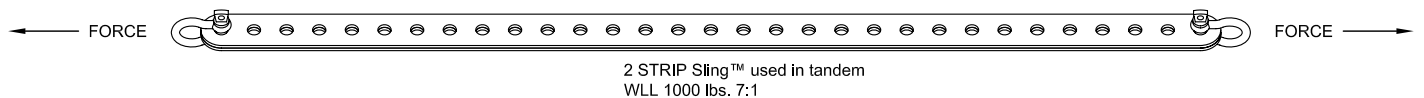
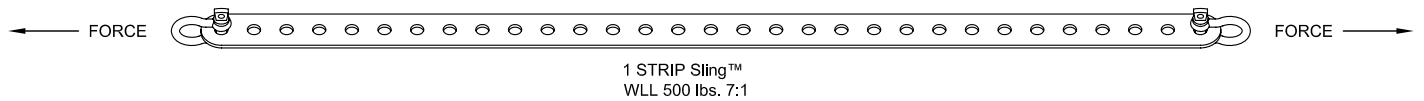

### NOTE:

The STRIP Sling™ may be shortened to desired length by shearing or sawing. An end cap is provided to cover the cut end. The cap also functions as a friction brake, when placed next to a fastener, inhibiting the rotation of the the STRIP Sling™.

Cutting must only be done within the area of a hole.

The STRIP Sling™ and associated shackles must all lie on the same plane.

Do not bend the strip or wrap shackles around a corner. See example above.

STRIP Sling™ bridles must have an included angle of 120° or less.

An included angle greater than 120° voids the load rating.

