

Use the speaker manufacturer's literature to determine if the factory rigging points are 3/8" or M10 metric screw size. **CAUTION!** a 3/8" screw can be mistakenly threaded into an M10 thread.

Work Load Limit 160 lbs. *

PATENT PENDING

* Refer to page 3 for additional information.

Advantage Products Enterprise, Inc.
 Single point suspension for Pro Audio speaker installation
 Three axis adjustable - Pan, Tilt and Rotation

Instruction Manual - U Tube™ - CTF

DO NOT ATTEMPT TO USE THIS PRODUCT BEFORE READING AND UNDERSTANDING THE INSTRUCTIONS.
 IF YOU HAVE ANY QUESTIONS, CONTACT **APE** @ 561-741-8126

USE OF THIS HARDWARE INVOLVES THE OVERHEAD SUSPENSION OF EQUIPMENT.
 AN OVERALL REVIEW OF YOUR PLAN AND METHOD OF ATTACHMENT TO THE STRUCTURE SHOULD BE DONE BY A LICENSED PROFESSIONAL ENGINEER. THE INSTALLATION SHOULD ONLY BE DONE BY QUALIFIED INDIVIDUALS WITH THE KNOWLEDGE AND PROPER TOOLS TO INSURE A RELIABLE OUTCOME.

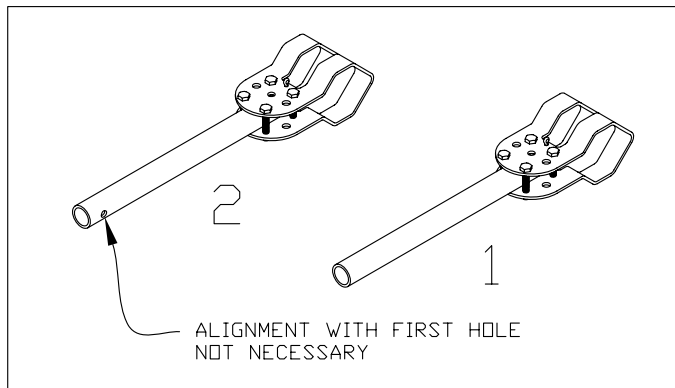

STEP 1

USER PROVIDED COMPONENT - 3/4" SCH. 40 STEEL PIPE

(1) Cut pipe to length and place end into Drill Guide/Gimbal and tighten screws. Be sure that pipe is against end stop. If cut end is not square, locate high point against end stop to ensure proper location. Using 5/16" drill bit provided, drill hole thru side of pipe at 5/16" guide hole location. Turn assembly over and drill hole thru opposite side of pipe. Do not attempt to drill completely thru assembly from one side.

(2) Reverse ends of pipe and repeat operation.

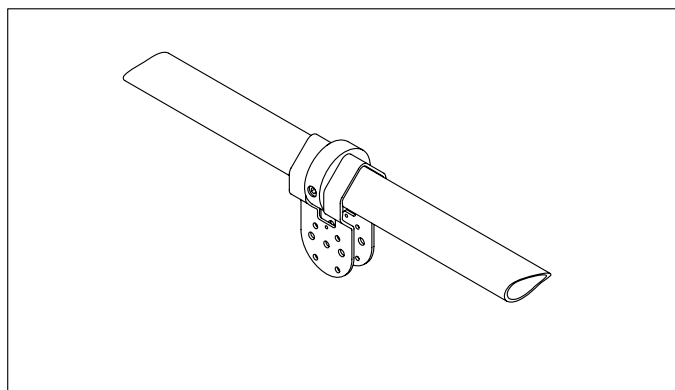

STEP 2

See note 3 on this page.

Remove 4 screws and cotter pin from Drill Guide/Gimbal and discard.

Slide the Gimbal and Set Screw Collar onto, user provided, beam.

Gimbal will accommodate pipe sizes thru 2" or 1 5/8" Unistrut channel.

Beam size required, will vary with span and load. Consult a licensed professional engineer to review beam size and attachment to structure.

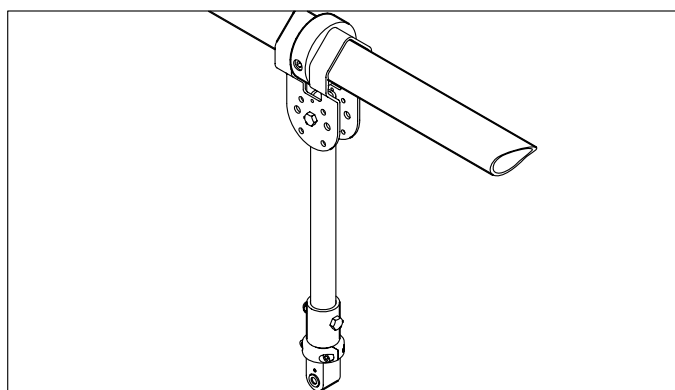

STEP 3

Attach 3/4" pipe stem to Gimbal with 5/16 x 2" cap screw and locknut provided. Tighten enough to remove play in connection but still allow pipe to pivot when pressure is applied. Note: The bolt may not fit into the hole of a Gimbal that has not been used as a Drill Guide.

Attach the Swivel Assembly to 3/4" pipe stem with 5/16 x 2" cap screw and locknut provided.

NOTE:

Use of any substitute hardware in the System voids load rating.

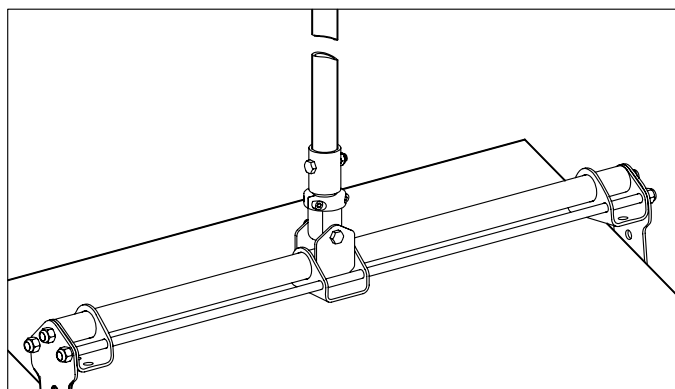

STEP 4

Prepare speaker as shown on pages 1 and 3.

Hoist speaker and attach the Rotation Traveler to swivel assembly with 5/16 x 2" cap screw and locknut provided. Tighten only enough to remove play in connection but still allow Rotation Traveler to pivot when pressure is applied.

We recommend using a compact electric chain hoist such as the CM Shopstar for hoisting speakers. Attach small web slings approx. 6" to the side of the stem assembly, one around the Beam and one around the Transverse Tube. Insert hoist between these two points and lift speaker into position.

NOTES

1. All user provided pipe shall be **Steel**, schedule 40 minimum, ASTM A53 Grade A with a yield strength not less than 30 ksi. Pipe sizes are nominal ID, actual OD of pipe is as follows: 3/4" pipe = 1.05" OD, 1 1/2" pipe = 1.9" OD, 2" pipe = 2.375" OD
2. The V shaped design of the contact surfaces on the Gimbal allow it to sit securely on a range of pipe sizes. The Set Screw Collar however, will only fit one size of pipe. Unless a different size is specified at time of order, the U Tube™ is shipped with a Set Screw Collar for 1 1/2" pipe.
3. The Drill Guide/Gimbal is a limited use tool and is intended to produce only 1 pipe stem. If it becomes necessary to produce multiple pipe stems using the same Drill Guide, care must be taken that the 5/16" hole does not begin to enlarge from overuse. If the diameter of the hole enlarges beyond 3/8", the Drill Guide/Gimbal must not be used to suspend a load. A replacement can be ordered from Advantage Products. A Drill Guide TOOL is available for repeated use. It can also be used to add holes to the bottom of a stem that has already been installed, making the Drill Guide/Gimbal unavailable.

U Tube™ - CTF (cut to fit)

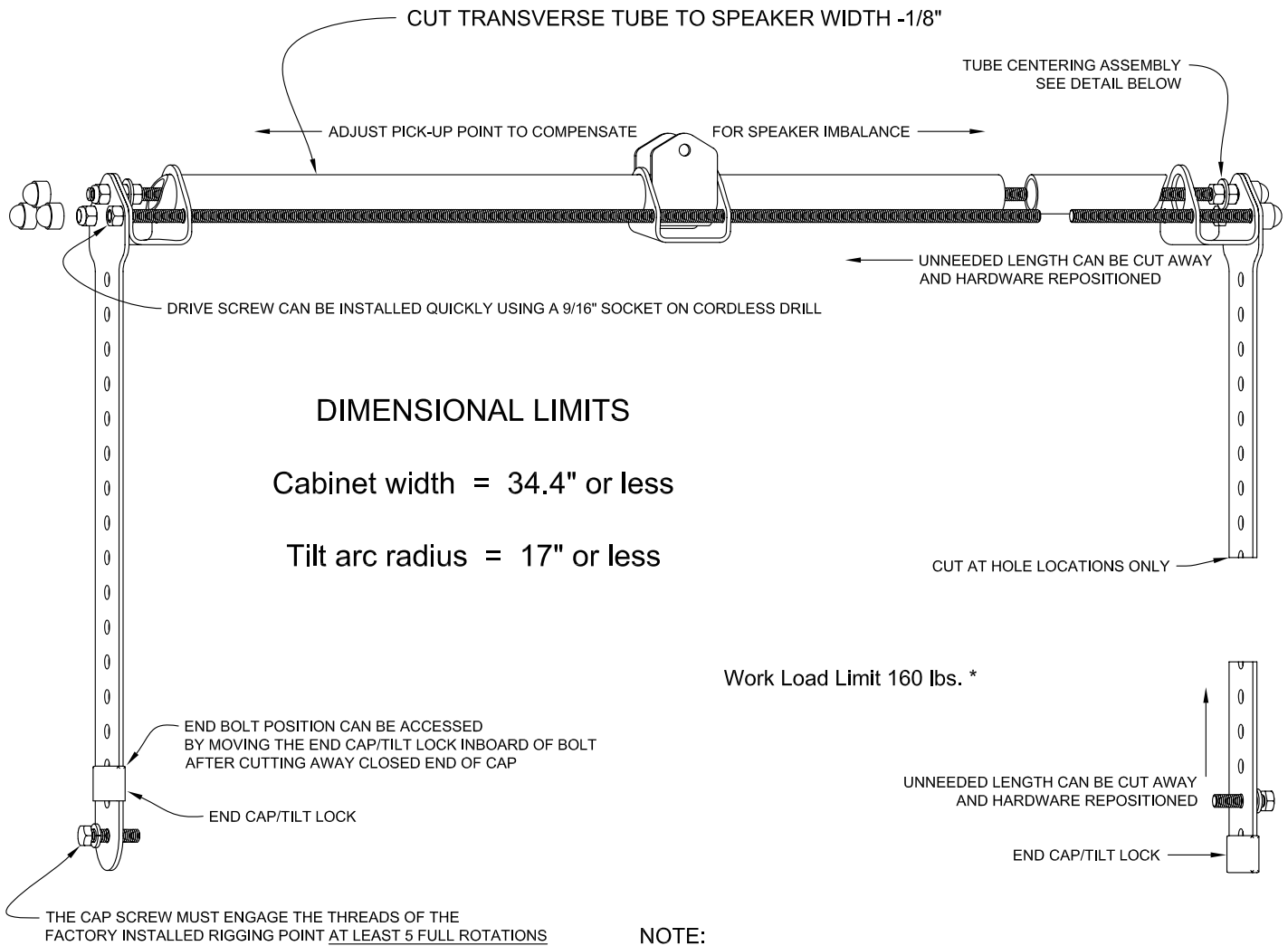

NOTE:
The Transverse Tube freely rotates within its supporting assembly, automatically compensating for any front to back speaker imbalance.

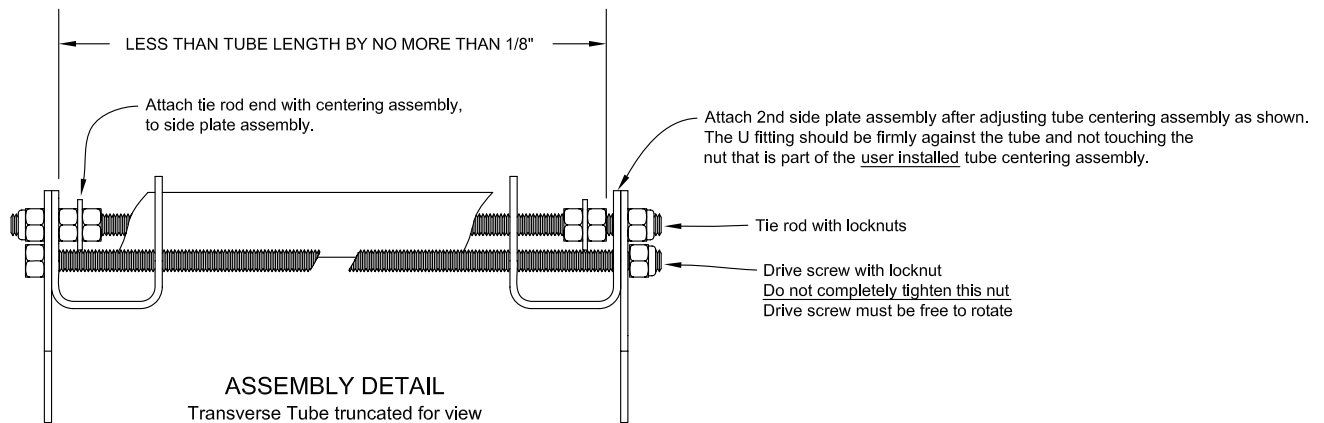

* The load rating was established by limiting the deflection of the Transverse Tube to less than 1/240 of its length. The yield point of the Transverse Tube, the point at which the deflection starts to become a permanent bend, is at least 3 times the load rating. A total failure of the system is at least 7 times the load rating.

NEVER EXCEED THE MAXIMUM LOAD RATING!

SAFETY CABLES

The following is not intended to be an exhaustive review of the techniques used to rig backup suspension systems. It is presented only to stress the importance of such systems and offer some basic guidelines.

1. Having an adequate Factor of Safety on the primary rigging components is essential, but it may not be able to compensate for installer error or damaged equipment. Only an effective backup system can keep these unforeseen occurrences from turning into catastrophes.
2. Always use safety cables designed and installed as though they were going to be relied upon to protect life and/or property.
3. As with the rigging of the primary suspension system, the installation of the safety cables should only be done by qualified individuals with the knowledge and proper tools to insure an effective outcome.
4. Select a wire rope size that has a Work Load Limit several times the speaker's weight. The same applies to all hardware used to secure the safety cable.
5. Keep the safety cable as vertical as possible, and with the least amount of slack possible.
More slack = more shock load = the need for stronger cable and attachments.
6. Attach the wire rope to the structure being careful to avoid sharp edges. Use softeners or chain slings as needed.
7. To limit slack in safety cable, do the following when making the speaker cabinet attachment:
 - Prepare an attachment point(s) on the upper most portion of the speaker and as centered on the speaker's mass as possible. A horizontally oriented speaker may require two attachments, one on each end, where no central rigging point is available. Alternately, a bridle can be used to provide a central rigging point.
 - Extend the safety cable down from the structural attachment to the speaker and form a loop in the cable at the point where it is just long enough to be shackled to the attachment point.
 - Using a felt tipped pen, mark both halves of the loop so it can be re-formed in exactly the same spot even if the cable needs to be moved to another area to apply the mechanical splice.
 - Make final connection between cable and speaker with shackle or other load rated connector. Using this method, a safety cable with 2" of slack or less is easily produced. **ALWAYS USE SAFETY CABLES**

For many installations, the point for the safety cable can also be used for the hoist point, if it is positioned far enough above the speaker location to accommodate the hoist. This can more than offset the cost of rigging the point when it is time to hoist the speaker(s) into position. Planning ahead to use the system in this way, can save many hours of labor to setup a temporary hoist point or platform.